

# New LSM microscopes

–

## Adaptation of Strip-FRAP

Protocol 3<sup>rd</sup> floor LSM510:

Feb-2005

1) Switch on system (remote switch), general login  
Computer

2) Click LSM510 icon – Scan New Images

Start Expert Mode

3) Acquire – Laser : Laser Control:

Switch on Argon Laser 488, (prewarming), adjust output  
(%) to tube current = **6.1 A**

4) Acquire – Micro : Microscope Control:

Microscope Settings: GFP

**Objective: 40x/Oil**

**Reflector: none**

**Tube Lens: Lens LSM**

- close window

5) Acquire – Configuration : Configuration Control:

**Channel Mode**

**Single Track**

Filter:

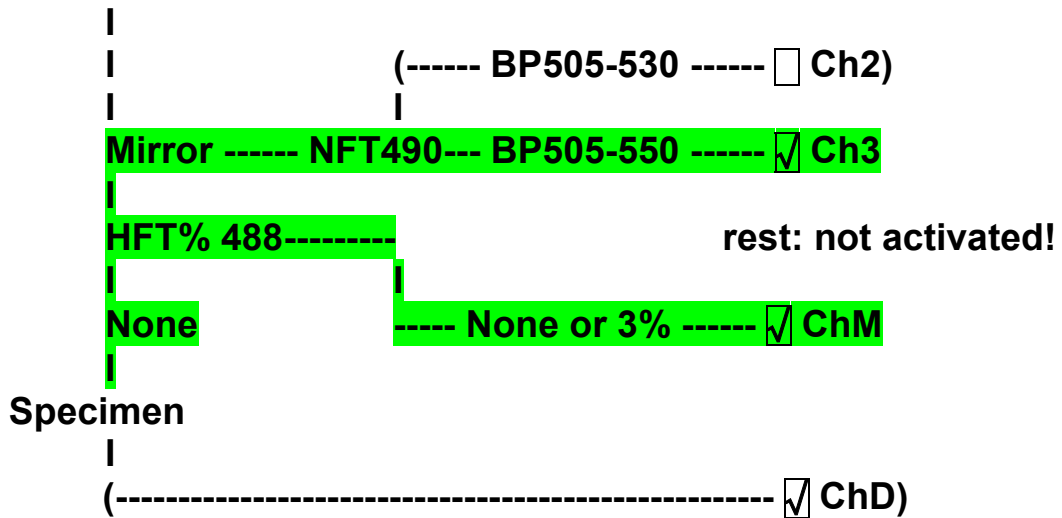

6) **Acquire** – **Vis** : find your cells in transmission light (microscope)

- **LSM**

7) Configuration Control:

(Possibility to switch on  **ChD** = transmission light to easier find cells via **Find** ; (Careful: **Find** alters some of your settings, like Detector Gain!)

Scan Control:

during finding of cells, pinhole can be put to max.

- switch off  **ChD** ), → **Single**

8) **Acquire** – **Scan** : **Scan Control**: **Frame**

Channels:

488 nm to **0.XX%** (~ 500-800 nW, measure with external laser meter! This laser power is around 21-22 in internal measure ChM)

Pinhole : to **Optical Slice = 2  $\mu$ m**

Detector Gain = **904**  
Amplifier Offset = **0.1**  
Amplifier Gain = 1

Data Depth = **8 Bit**  
Scan Direction = **→**  
**Scan speed = 9!**

If low fluorescence: you can use Sum 2-4 for finding cells at Zoom 1 or 0.7 (Careful: zoom 0.7 alters scan speed to 8!)

Center cells: 1<sup>st</sup> use **Gert-Center** in **Macros**, to center your desired cell, zoom in to 3 or 6.

**→ Gert-Center off!**

At Zoom 3-6: **→ Z-stack** **→ Range**

- set middle line to fluorescent cell middle (in fact a little closer to the glass slide line)

**→ XY scan**

**→ Z-stack off!**

Center cell carefully with **Crop** function in image window, to **Zoom = 6**. Be sure that the cell is straight upright (rotate it, if necessary!), and the Crop-Cross well in the center of the nucleus!

9) put Sum back to 1!

→ **use ROI** :

**Acquire** → **Edit ROI** :

Y = 10 pixels

X = adaptable to cell width

(center ROI to x=256, y=256)

→ save ROI to list or use **ROI from list** by clicking on it (**strfr**100 etc.)!

10) **Acquire** → **Edit Bleach** : Bleach Control:

**Define Region**: click on (proposed) region = same as for Acquire!

11) Bleach Control:

Settings: **bleach after scan number** **200** =~4 sec

488 nm = **100%**

Iterations: **1!** (= 20msec)

12) **Acquire** → **Time Series** : Start Series : **Manual**

Stop series: **Manual** Number 4000 (≈80 sec), 2100 (≈40 sec), or 1100 (≈20 sec)

**Time Interval = 20 msec**

13) → **Mean ROI** in Time series control!

14) Save image in MDB file

## Trouble Shooting:

- 1) 1st time **Mean ROI** does not give any bleaching = “bug in the programme”! Solution: press 1<sup>st</sup> time **StartB** instead of **Mean ROI** in Time series Control, let run for a few seconds, then take image of your cell again, activate ROI and normally press **Mean ROI** !
- 2) Scan Speed switches from 9 to 8: can happen, if you decrease Zoom below 1, or go too far to the edge of your field of examination (at low zoom). Be sure to switch back to zoom=9, before you start your time series, otherwise the timing is incorrect!
- 3) You loose focus, or **Mean ROI** cannot be activated: switch off **Z-stack** ! Switch off center-macro!

Feb 2005

Angelika Zotter